

# Graymills

PARTS WASHER CATALOG



: solvent : solvent/aqueous : aqueous : bioremediation : ultrasonic : cleaning fluids : accessories : custom systems :

Graymills.com

1.888.GRAYMILLS

## Selecting the right parts washer

Both your Graymills distributor and our factory staff are prepared to offer any assistance in selecting your parts cleaner. The more of the following information you furnish, the quicker—and more precisely—the appropriate parts washer can be selected.

- Soils to be removed.
- Current cleaning method used.
- Material(s) from which your parts are manufactured.
- Size, weight, configuration and quantity of the parts to be cleaned per day.
- Operations immediately before and after cleaning. (e.g., “machine before/paint after.”)
- Preferred method of handling: manual or automatic.
- Single or multi-step cleaning required.
- Type of cleaning fluid: solvent or water-based.

## Choosing your cleaning action

<b>A</b> SOAK	<b>B</b> BRUSH	<b>C</b> DIRECTED STREAM	<b>D</b> HIGH PRESSURE SPRAY
<p>Soaking is the simplest, least aggressive cleaning action. It is more effective with longer immersion time. This cleaning action is applicable where soils are easily removed and where low equipment cost is important.</p>	<p>Manual brushing is used as a supplement to other cleaning actions. This method is helpful in removing stubborn soils in hard to reach places. An assortment of parts cleaning brushes is available in the ACCESSORIES section. See accessories page 28-29.</p>	<p>A flexible hose is used to direct a flushing stream of low pressure cleaning fluid directly at the soiled part. This cleaning action is particularly effective for flushing parts when brushing. For maximum results, the directed stream action can be used in combination with other cleaning actions. Some models feature a second hose with a pistol grip nozzle, which provides an adjustable flushing spray.</p>	<p>Quick and effective cleaning is accomplished by a powerful spray of heated, water-based cleaning solution. The high pressure spray blasts away the toughest deposits without damaging precision parts.</p>
<b>E</b> TURBO FLUID AGITATION	<b>F</b> LIFT PLATFORM AGITATION	<b>G</b> HEATED	
<p>This cleaning action is a result of the constant movement of the solution through and around the soiled parts. It provides faster cleaning than manual applications. A variety of pump and air circulated systems are available for fluid agitation.</p>	<p>A “scrubbing” action is achieved by continually moving the parts vertically through the cleaning fluid. The motion is accomplished by a pneumatically operated platform in the tank. The system is automatic. The cleaning action is intensified when used in combination with Turbo fluid agitation (see page 17). It is ideally suited for a wide range of cleaning tasks.</p>	<p>(Water based solution only) The effectiveness of water based cleaning solutions increases dramatically as the temperature increases. The optimum recommended temperature is governed by the equipment and the particular detergent used.</p>	

## Catalog Contents / Selection Guide

catalog contents/selection guide

PAGE NO.	AVAILABLE CLEANING ACTION --->	A	B	C	D	E	F	G
		SOAK	BRUSH	DIRECTED STREAM	HIGH PRESSURE SPRAY	IN-TANK FLUID AGITATION	LIFT PLATFORM AGITATION	HEATED (AQUEOUS ONLY)
5	<b>SOLVENT</b>							
5	EC-A	*	■	*				
5	HK150	*	■	*				
6	DM232/236		■	*				
7	PL36	*	■	*				
7	PL422	*	■	*		*		
8	Clean-O-Matics	*	■	*		*		
10	<b>SOLVENT / AQUEOUS</b>							
11	Turbo-Series T24/36	*	■			■		■
11	Turbo-Series T4330-thru T8430	*				*		■
14	T-Series Liftkleen T2420-T3626	*	■			■	*	■
15	L-Series Liftkleen L36 thru L72	*				■	*	■
16	Oil Separators							
17	Turbo Boost / Roto Basket							
18	Custom Systems							
19	<b>AQUEOUS</b>							
19	Tempest 10/20		■		*			*
20	DH226		■	*				*
20	PH822	*	*	*				*
21	DH536R		*	*				*
21	DH436R		*	*				*
22	<b>BIOREMEDIATION / AQUEOUS</b>							
23	BIO436R/536R		*	*				*
24	<b>ULTRASONIC / AQUEOUS</b>							
24	Benchtop BTU-4, -7, -17	*	■					*
25	Sonic Liftkleen TU2420SL	*	■				*	*
26	Liftkleen Super Sonic TUS3725SL	*	■				*	*
28	Accessories							
30	Fluids							

\* STANDARD ■ OPTIONAL

# Why Graymills?

Why should you select a Graymills parts washer instead of one of the other brands? Here are a few things you should consider when making your purchase:

- 1 Graymills is a family-owned and operated company, founded in 1939. Quick response when you need it. No corporate red tape.
- 2 We manufacture in our own 90,000 sq. ft. plant, centrally located in Chicago. Our own engineers design the equipment we make.
- 3 Average length of employee service in our plant is around 12 years. That experience goes into every parts washer we make.
- 4 In order to control quality and on-time delivery, manufacturing is done by state-of-the-art equipment:
  - All metal cutting is done by a laser for accurate, clean-cut parts.
  - Welding is either mig or tig for strong welds.
  - Every welded seam is leak-tested—that's 100%. While the test criteria is 8 hours, we leave our tanks sit for 24 hours. Just to be sure.
  - After passing the leak test, every tank is power-washed with a solution that assures aggressive bonding of the paint to the sheet metal.
  - Our finish is epoxy polyester hybrid powder paint, oven-cured at 410° F for 25 minutes. We think you'll be more than happy with this finish for a long time.
  - Because we've put a lot into these "Made in America" parts washers, we want you to receive it the way it looked when we finished building it. We go to great lengths to make sure our packaging provides safe transit to your door (except for the time they dropped the box off the truck tail gate).
  - Do we make mistakes? Sure. When we do, you'll find our Chicago-based, experienced Customer Service department anxious to correct the mistake and quickly get you up and using your equipment.

It may sound "hokey" now that we are in the 21st Century—but I think when you use your Graymills parts washer, you'll understand why we've called them, "The Friend Maker" since 1940.



Craig Shields  
*President*

# Econo-Models



Economical solvent cleaner for professional or home shop use in a convenient, portable size.

Standard features : EC-A :

- **Flexible Stay-Put metal flush hose** for directable hands-free flushing action
- **Industrial-grade steel** tank with durable powder-coat finish for **durability** and long-life
- **Fusible safety link** closes lid in event of fire
- **Removable lid/cover** for **easy access** to pump and easy cleaning of tank

<b>EC-A</b>	<i>Econokleen Benchtop Parts Washer</i>	
MODEL NO.	OPERATING FLUID CAP.	MOTOR
EC-A	3-5 gal	115V, 60 Hz, 1 Ph

Full-sized free-standing unit offers professional features in an economical package. Ideal for general maintenance and repair in industrial, automotive, marine or farm applications.

Standard features : HK150 :

- **Abrasive-resistant pump** delivers **400** gallons per hour flow rate; pump motor is not exposed to the cleaning solution - eliminates need for pump seals
- **Flexible Stay-Put metal flush hose** for directable hands-free flushing action
- Standard **filtration** includes sludge collection basket with dual foam filter to keep solution cleaner longer
- **Removable 30" x 18" internal work shelf** sits above cleaning solution for easy manual cleaning and parts visibility; remove to access soak tank
- **Bottom drain** for easy fluid change-outs
- **Fusible safety link** closes lid in event of fire
- **16 gauge steel** tank with powder-coat finish for durability and long-life
- **Removable legs** for conversion into bench-top unit

Optional : HK150 :

- **External drain shelf** to drain cleaned parts. Cleaning solution flows from parts back into the cleaning reservoir (see Accessories page 28-29)



<b>HK150</b>	<i>Free-standing Professional Parts Washer</i>	
MODEL NO.	OPERATING FLUID CAP.	MOTOR
HK150-A	2 1/2 -5 gal	115V, 60/50 Hz, 1 Ph

# Drum Mount



DMD 232

### Standard features : DM232/236 :

- **Abrasive resistant 170 GPH pump**
- **Reusable nylon filter** system removes large particles of dirt and grime to keep fluid clean longer
- **Flexible Stay-Put metal flush hose** for directable hands-free flushing action
- **Metal drain strainer** keeps small parts from falling into cleaning solution tank
- **16 gauge steel** tank with **powder-coat** finish for durability and long-life
- **Lift-off sink** for easy setup and maintenance; fast cleanup and fluid changes
- Built **two inches taller** than competition to eliminate bending/stooping—strain-free use!
- Available in **16 & 30 gallon** drum sizes
- **Fusible safety link** closes lid in event of fire

### DMD deluxe model :

- Deluxe models have a **patented retractable pump** to avoid back strain when removing tank from drum because tank needs to be lifted only a few inches from drum. With pump inside mounting ring, tank sits flat on bench or floor, saving **pump** from abusive shocks or accidental mishandling
- **Worklight** is designed so it cannot be pulled down to obstruct the cover from closing

DMD/DMS  
232/236

*Spacious recirculating parts washer can be placed at jobsite for on-the-spot cleaning.*

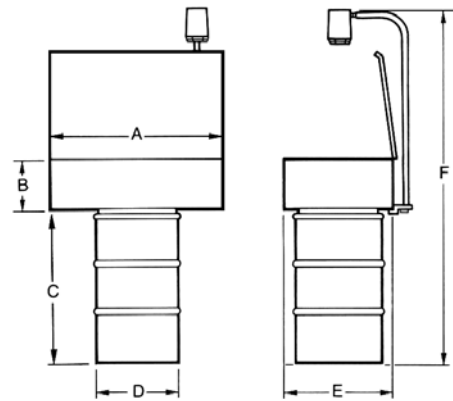

MODEL NO.	A	B	C	D	E	F
DMD/DMS 232	32"	8 <sup>3</sup> / <sub>4</sub> "	28 <sup>1</sup> / <sub>2</sub> "	14 <sup>1</sup> / <sub>2</sub> "	18"	65"
DMD/DMS 236	36"	8 <sup>3</sup> / <sub>4</sub> "	30 <sup>3</sup> / <sub>4</sub> "	19 <sup>1</sup> / <sub>4</sub> "	20"	67 <sup>1</sup> / <sub>8</sub> "

DESCRIPTION	DM 232 MODELS	DM 236 MODELS
Operating Fluid Capacity	5-10 gal	10-20 gal
Drum Capacity	16 gal	30 gal
Motor	115V, 60 Hz, 1 Ph	

Graymills  
Patented

Retractable Pump

Reduces Lifting Height to Minimize Back Strain

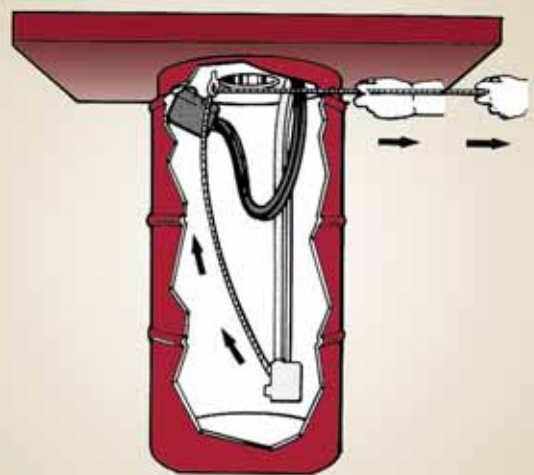

# Handi-Kleen

Versatile unit optimizes flush hose and hand-held brush cleaning, sloped work shelf, small parts basket and optional external drain shelf. 15 gallon tank has bottom drain for easy maintenance.

**PL36** *Combination of solvent scrub station and soak tank*

MODEL NO.	OPERATING FLUID CAP.	MOTOR
PL36-A	8 1/2 - 20 Gal	115V, 60/50 Hz, 1 Ph



Standard features : both models :

- 400 GPH Graymills Superflo pump
- Filter and sludge collector basket with dual-element foam filter keeps fluid cleaner longer for fewer change-outs
- Flexible Stay-Put metal flush hose for directable hands-free flushing action
- 16/18 gauge steel tank with durable powder-coat finish for durability and long-life
- Bottom drain convenient for fluid change-outs
- Small parts basket
- Fusible safety link closes lid in event of fire

Additional features : PL36 :

- Removable work shelf for parts cleaning above fluid or soaking in solvent tank

Additional features : PL422 :

- In-tank air manifold agitates the solvent to loosen dirt and pre-clean parts
- Two-piece sliding, solid metal work shelf extends over the entire tank to provide a 34 1/2" x 20 3/16" work surface as well as to reduce solvent loss due to evaporation. Sliding the right shelf over the left creates an 18" x 21 1/2" soak tank with an equal size work area. Or store both shelves in the side slot for a fully-open soak tank
- The in-tank metal grate perfectly positions parts above sludge on bottom
- Unique safety device cuts off air flow to manifold in unlikely event of fire

An in-tank air manifold agitates the solvent to loosen dirt and pre-clean parts. The in-tank metal grate perfectly positions parts above sludge on bottom—exposing all surfaces to agitation for more effective cleaning.

**PL422** *With solvent recirculating pump and in-tank air agitation manifold*

MODEL NO.	OPERATING FLUID CAP.	MOTOR
PL422-A	20-40 Gal	115V, 60/50 Hz, 1 Ph

Optional : PL36-422 :

- External drain shelf will drain solution to tank and reduces drying time.

See Accessories page 28-29

# CLEAN-O-MATIC

## Clean-O-Matic: The Industry Standard for more than 50 years

Ruggedly constructed for years of trouble-free solvent cleaning service. These feature-packed models offer a variety of design elements to make your cleaning tasks quicker and more efficient while remaining flexible enough to suit most cleaning challenges.

The Clean-O-Matic Series progresses in size and power from the 300-A, with a 1/8 horsepower pump and 42-gallon capacity, to the 902-A, with two 1/3 horsepower pumps and 117 gallon capacity.

All models feature three way cleaning—pump for in-tank agitation that loosens dirt/grime on soaking parts; pistol grip nozzle for flushing away contaminants; and Flexible Stay-Put flush hose in conjunction with a hand-held brush.



500-A

- > **Three-way cleaning action** selector valve permits using pump, pistol grip spray nozzle or flush hose cleaning actions individually or in combination
- > **In-tank agitation** loosens dirt and grime as parts soak.
- > **Pistol grip spray nozzle** is adjustable for light spray or solid stream—direct where cleaning and rinsing of parts is needed
- > Adjustable bi-level **work shelves**
- > Graymills **abrasive-resistant pump** has no bearings/seals immersed in fluid—extends pump life
- > **Washable 40 mesh screen solvent filter**
- > The **in-tank metal grate** perfectly positions **parts above sludge** on bottom
- > Two optional **removable soak/sludge trays** keep soaking parts off bottom—makes sludge removal easier
- > **Extra long Stay-Put flexible metal flush hose** for directable hands-free flushing action.
- > **Drain plug**
- > **Safety lid** shuts automatically in case of fire—or close to reduce fluid evaporation
- > **Rugged 16 gauge** powder-coated steel construction

(Optional Accessories, see pages 28-29)



All models include features shown on page 8.

**300-A**  
**500-A**

*The maintenance and repair shop standard*

MODEL NO.	OPERATING FLUID CAP.	MOTOR
300-A	16-42 gal	1/8 HP, 115V, 60/50 Hz, 1 Ph
500-A	16-42 gal	1/3 HP, 115V, 60/50 Hz, 1 Ph

both models : 300-A + 500-A :

- 44" L x 21" W x 23<sup>3</sup>/<sub>4</sub>" H work space
- 16-42 gallon capacity
- Casters allow unit to be easily moved

**300-A :**

- 1/8 HP Graymills Superflo pump, 1000 GPH
- Pump provides in-tank fluid agitation

**500-A :**

- 1/3 HP, Graymills Superflo pump 2400 GPH
- Pump with Hydro-Jet Manifold provides active in-tank fluid agitation

**800-A**

*All the operating features of the 500-A in a tank with twice the fluid capacity*

MODEL NO.	OPERATING FLUID CAP.	MOTOR
800-A	50-85 Gal	1/3 HP, 115V, 60/50 Hz, 1 Ph

**800-A :**

- 41<sup>3</sup>/<sub>8</sub>" L x 28<sup>7</sup>/<sub>8</sub>" W x 29<sup>1</sup>/<sub>2</sub>" H work space
- 50-85 gallon capacity
- 1/3 HP, Graymills Superflo pump 2400 GPH
- Pump with Hydro-Jet Manifold provides active in-tank fluid agitation

**900-A**  
**902-A**

*These large units handle parts like engine blocks, transmissions and compressors; 902-A has two 1/3 HP pumps*

MODEL NO.	OPERATING FLUID CAP.	MOTOR
900-A	50-117 gal	1/3 HP, 115V, 60/50 Hz, 1 Ph
902-A	50-117 gal	1/3 HP, 115V, 60/50 Hz, 1 Ph

both models : 900-A + 902-A :

- 49" L x 28<sup>1</sup>/<sub>2</sub>" W x 33<sup>3</sup>/<sub>8</sub>" H work space
- 50-117 gallon capacity
- Pump with Hydro-Jet Manifold provides active in-tank fluid agitation

**900-A :**

- 1/3 HP, Graymills Superflo pump 2400 GPH

**902-A :**

- Two 1/3 HP, Graymills Superflo pumps 2400 GPH each, provide aggressive in-tank fluid agitation through dual Hydro-Jet Manifolds—operate independently or together

# TURBO ACTION



The Turbo-Action Series from Graymills is the perfect solution for hands-off, immersion cleaning required for challenging parts cleaning applications. Turbo-Action total immersion parts cleaners convert the jet stream from Graymills Superflo pumps into powerful, hands-off fluid action that gets parts cleaner without manual handling or scrubbing. Unlike spray cabinet type cleaners that employ spray nozzles, total immersion cleaners bring cleaning action to every external and internal surface—even blind holes. Turbo-Action units scour and flush parts clean and are offered in both solvent and heated aqueous versions with pumps that provide up to 10,000 GPH. The heated aqueous units come standard with energy-savings insulation and corrosion-resistant insulated stainless steel-lined lids.

A variety of tank sizes and options including stainless steel tanks, filtration systems and baskets ensures the Turbo-Action Series can handle your largest cleaning task, including cylinder heads, transmission housings, heavy castings, and complex parts.

- Total parts immersion provides **hands-off cleaning** without operator involvement
- **Grid platform** supports parts above bottom—allows for **all sides** of parts to be **exposed to cleaning solution**
- Two-inch drain for **easy fluid change-out**
- Multiple tank sizes up to **262 gallon** capacity
- **Solvent or aqueous** models available; some models can be **field-retrofit** and converted to aqueous versions if cleaning method changes.
- Fusible **safety link** closes lid in event of a fire
- Variety of options available to handle almost any application: **filtration systems, stainless steel tanks, baskets** (See Accessories pages 28-29)

# Turbo Units

The efficiency of immersion cleaning allows more time for the cleaning solution to do the work, provides penetration into blind holes, nested or layered parts, maximizes soak time to loosen contamination, and the Turbo Action of the pump adds to the speed and efficiency of the cleaning process.

## TURBO 24/36

*The T24 and T36 are Graymills most economical total immersion cleaners and are offered in both solvent and aqueous (heated) versions.*

MODEL NO.	A	B	C	D	E	F	G
T24	25 <sup>1</sup> / <sub>2</sub> "	39"	34"	66"	22"	24 <sup>1</sup> / <sub>2</sub> "	12"
T36	35 <sup>1</sup> / <sub>2</sub> "	50"	34"	75"	27"	29 <sup>1</sup> / <sub>2</sub> "	18"

DESCRIPTION	T24	T36
Immersion Space (L x W x D)	24" x 20 <sup>1</sup> / <sub>2</sub> " x 12"	34" x 25 <sup>1</sup> / <sub>2</sub> " x 18"
Overall Dimensions (L x W x H) (lid open)	39" x 24 <sup>1</sup> / <sub>2</sub> " x 66"	51" x 29 <sup>1</sup> / <sub>2</sub> " x 75"
Liquid Capacity (gal)	47	118
Motor/Pump (Hp)	1 <sup>1</sup> / <sub>2</sub>	1 <sup>1</sup> / <sub>2</sub>
Gallons Per Hour	3000	3000
Voltage	115/230/460V	115/230/460V
Hertz Phase	60/50-1 or 3 Ph	60/50-1 or 3 Ph
Heater for water-based cleaning only (60° - 180° F (15° - 82° C))	6.75 kW	6.75 kW

## TURBO 4330- 8430

*With five tank sizes and liquid capacities up to 262 gallons, the largest "Turbo Series" is also available in solvent or aqueous versions. 10,000 gallon per hour flow ensures effective scouring and cleaning of parts.*

MODEL NO.	A	B	C	D	E	F	G
T4330	39 <sup>1</sup> / <sub>2</sub> "	56 <sup>1</sup> / <sub>2</sub> "	37"	67"	27 <sup>1</sup> / <sub>2</sub> "	30"	23 <sup>1</sup> / <sub>4</sub> "
T5430	49 <sup>1</sup> / <sub>2</sub> "	66 <sup>1</sup> / <sub>2</sub> "	37"	67"	27 <sup>1</sup> / <sub>2</sub> "	30"	23 <sup>1</sup> / <sub>4</sub> "
T6430	59 <sup>1</sup> / <sub>2</sub> "	76 <sup>1</sup> / <sub>2</sub> "	37"	67"	27 <sup>1</sup> / <sub>2</sub> "	30"	23 <sup>1</sup> / <sub>4</sub> "
T7430	69 <sup>1</sup> / <sub>2</sub> "	86 <sup>1</sup> / <sub>2</sub> "	37"	67"	27 <sup>1</sup> / <sub>2</sub> "	30"	23 <sup>1</sup> / <sub>4</sub> "
T8430	83"	96 <sup>1</sup> / <sub>2</sub> "	37"	67 <sup>1</sup> / <sub>2</sub> "	27 <sup>1</sup> / <sub>2</sub> "	30"	23 <sup>1</sup> / <sub>4</sub> "

DESCRIPTION	T4330	T5430	T6430	T7430	T8430
Immersion Space (L x W x D)	39 <sup>1</sup> / <sub>2</sub> " x 27 <sup>1</sup> / <sub>2</sub> " x 23 <sup>1</sup> / <sub>4</sub> "	49 <sup>1</sup> / <sub>2</sub> " x 27 <sup>1</sup> / <sub>2</sub> " x 23 <sup>1</sup> / <sub>4</sub> "	59 <sup>1</sup> / <sub>2</sub> " x 27 <sup>1</sup> / <sub>2</sub> " x 23 <sup>1</sup> / <sub>4</sub> "	69 <sup>1</sup> / <sub>2</sub> " x 27 <sup>1</sup> / <sub>2</sub> " x 23 <sup>1</sup> / <sub>4</sub> "	83" x 27 <sup>1</sup> / <sub>2</sub> " x 23 <sup>1</sup> / <sub>4</sub> "
Overall Dimensions (L x W x H) (Lid Open)	56 <sup>1</sup> / <sub>2</sub> " x 30" x 67"	66 <sup>1</sup> / <sub>2</sub> " x 30" x 67"	76 <sup>1</sup> / <sub>2</sub> " x 30" x 67"	86 <sup>1</sup> / <sub>2</sub> " x 30" x 67"	96 <sup>1</sup> / <sub>2</sub> " x 30" x 67 <sup>1</sup> / <sub>2</sub> "
Liquid Capacity (gal)	142	169	200	231	262
Pump(s) 1 <sup>1</sup> / <sub>2</sub> hp	1	1	1	1	2
Gallons Per Hour	10,000	10,000	10,000	10,000	20,000
Voltage	230/460	230/460	230/460	230/460	230/460
Hertz Phase	60/50-1 or 3 Ph	60/50-1 or 3 Ph	60/50-1 or 3 Ph	60/50-1 or 3 Ph	60/50-1 or 3 Ph
Heater for water-based cleaning only (60° - 180° F (15° - 82° C))	4.5 kW	4.5 kW	4.5 kW	4.5 kW	4.5 kW

# LIFTKLEEN™



T-Series

L-Series

## Why Immersion Cleaning is Preferred

Immersion cleaning is preferred... Unlike standard spray cabinet washers, immersion cleaning exposes all surfaces of the part, including blind spots and small crevices, to the cleaning solution. By combining hands-off, total immersion cleaning, easy part load/unload, vertical lift platform agitation and optional Graymills Superflo pump jet action, the Liftkleen offers the most intensive, efficient immersion cleaning system available. Complex parts, stacked or nested parts are no problem.

The T and L Series Liftkleens offers a variety of sizes and options, including pump, agitation, ultrasonics, and automatic control of cleaning cycles, that make it the easiest-to-use, large size cleaner on the market. One touch control of the pneumatic air system and electronic controls turns multi-function operation into a simple step.

## Customize the Liftkleen for your specific needs.

Options include: ➤ **Ultrasonic Models** to create energized bubbles for powerful small and large parts cleaning (see pages 24-27) ➤ High power Graymills Superflo pump for **in-tank fluid agitation** adds more turbulence to washing tank ➤ **Heaters and insulation** for aqueous units ➤ **Lift roller platform** aids in loading and unloading parts ➤ **Stainless steel tanks** ensure long life of unit ➤ **Oil Separator** to remove oil from aqueous cleaning solution during the cleaning process ➤ **Turbo-boost filtration** system filters and extends life of cleaning solution (see page 17) ➤ **Rotating** small parts **basket** for T-Series (see page 17)



### Standard Features for T-Series and L-Series Liftklean Models

- Both **Solvent** or **Aqueous** versions
- Air-operated **lift platform**
- **Stainless steel lined lids** on L and heated T-Series units
- Hands-off, **full immersion cleaning**; from simple soaking to lift platform agitation
- **Fully adjustable** lift platform **agitation**—speed and stroke length
- Lift mechanism is entirely outside of tank for **long service life**
- **Fiberglass grate**, mild steel or stainless steel optional

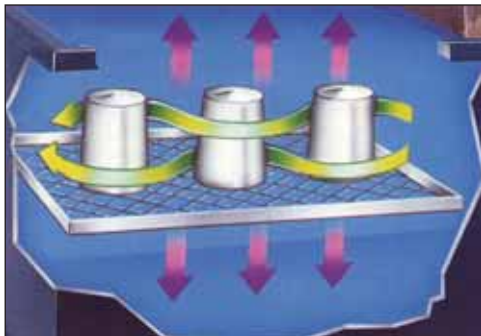

### Dual Action Cleaning Option – Shortens Cleaning Cycle up to 40%

- Optional **Superflo Pump** circulates up to **10,000 GPH**
- The **Dual Action cleaning cycle** combines vertical platform agitation with a Graymills Superflo centrifugal pump jet stream for **faster cleaning** including crevices, blind holes and recesses
- Dual Action cleaning is effective in both **cold solvent** and **heated aqueous** applications

### Hands-Off Automatic Operation with Liftklean



- Parts are **easily loaded** on platform at tank top level



- Start cycle **lowers parts** into solution
- **Fully immersed parts** may be soaked and/or agitated with programmable cleaning



- Optional **auto-lid** opens at end of cycle
- Platform **raises for draining** and easy parts removal



## T-SERIES 24/36

*Versatile, convenient size immersion parts washer with V-Shaped bottom and center drain for easy cleaning.*

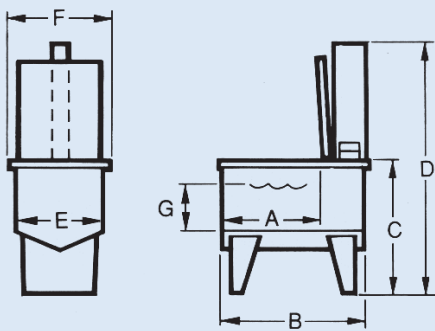

MODEL NO.	A	B	C	D	E	F	G
T2420	24"	39"	34"	66"	20 <sup>1</sup> / <sub>2</sub> "	24 <sup>1</sup> / <sub>4</sub> "	12"
T3626	34"	50"	34"	75"	25 <sup>1</sup> / <sub>2</sub> "	29 <sup>1</sup> / <sub>2</sub> "	18"

SPECIFICATIONS	T2420	T3626
Immersion Space (L x W x D)	24" x 20" x 12"	34" x 25 <sup>1</sup> / <sub>2</sub> " x 18"
Overall Dimensions (L x W x D)	39" x 24 <sup>1</sup> / <sub>2</sub> " x 66"	50" x 29" x 75"
Liquid Capacity	47 gal	118 gal
Dimensions	22" x 19"	32" x 24"
Standard Lift Capacity/PSI	125/90	200/90
Stroke Length	3"	3"
Air Inlet	1/4"	1/4"
Strokes Per Minute	60-80	60-80
Drain	2"	2"

OPTIONS	T2420	T3626
Pump Agitation Horsepower	1/2	1/2
Gallons per Hour	3,000	3,000
Voltage Options	115V, 230V, 460V	115V, 230V, 460V
Hertz Phase	60-1 or 3	60-1 or 3
Heating System (Electric Heat) (Range: 60-180F/16-82C)	6.75kW	6.75kW
Roller Platform	*	*
Filtration System	*	*

\* Available on this model, consult Graymills Price list for specs

## Liftkleen Series

The Liftkleen L-Series has been proven by years of tough field use in industrial, maintenance, heavy duty truck and automotive repair facilities. These automatic, agitating, immersion cleaning machines are solidly built for long service life. They are available for both heated aqueous and solvent cleaning applications.

Two Series—"L" and "T" serve unique needs. The "T" Series has a smaller footprint, liquid capacity and lift capability. They are widely used for job site "cell" cleaning in manufacturing, automotive and maintenance shops. With most of the same features as the "L" Series, they offer quick, thorough cleaning for smaller parts.

Graymills "L" Series picks up where the "T" Series leaves off. Choose from 5 tank sizes designed for larger parts, and heavier components (up to 1,850 pounds). All lift platform components are outside the tank, eliminating the most common reason for failure in many other machines. "L" Series Liftkleens are the workhorse of today's manufacturing, maintenance and repair operations. Air filter/regulator (FLR) comes standard with all T & L Series Liftkleen units.

### Special Options offered:

- > **Electric heat** (Aqueous Only) increases the cleaning capability of your aqueous solution with **optional heaters** available for up to **180° F (82° C)**
- > **Roller platform** aids in loading and unloading of parts
- > **High power** Graymills Superflo pump adds **in-tank fluid agitation**
- > **Turbo-boost filtration system** increases turbulence in wash tank and cleans sediment from wash tank while filtering the cleaning solution (see page 17)
- > **Ultrasonics** for critical detailed cleaning
- > **Extra lift capacity** accommodates parts up to 1850 pounds (L Series only)
- > **Pneumatic Cover with safety link** automatically raises and lowers at beginning and ending of wash cycle (L Series only)
- > **Anti-tie down device** incorporates a two-handed, air activated controller device to start cleaning process (L Series only)
- > **7-day heater timer** (Aqueous only) controls time you want heater to come on to preheat solution or stay off to save energy (L Series only)

# L-Series

solvent/aqueous

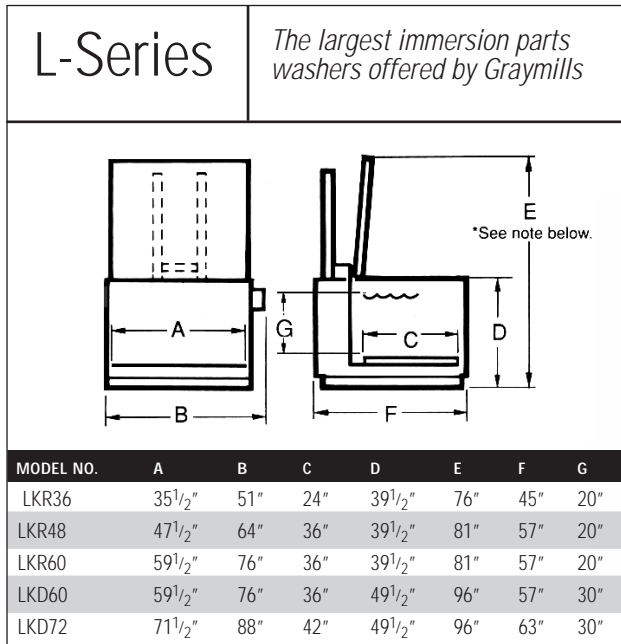

Industrial controls for wash cycle, heater, lift platform agitation and lid.

\* Maximum height for Model LKR36 is to top of mast. All other L-Series Liftklean use open lid as maximum height.

SPECIFICATIONS	LKR36	LKR48	LKR60	LKD60	LKD72
Immersion Space (WxDxH)	39" x 28" x 20"	52" x 39" x 20"	64" x 39" x 20"	64" x 39" x 30"	76" x 45" x 30"
Overall Dimension (WxDxH)	51" x 45" x 76"	64" x 57" x 81"	76" x 66" x 81"	76" x 66" x 96"	88" x 72" x 96"
Liquid Capacity	170	290	355	491	667
Platform Dimensions (WxD)	35½" x 24"	47½" x 36"	59½" x 36"	59½" x 36"	71½" x 42"
Standard Lift Capacity / PSI	550 / 100	450 / 100	700 / 100	700 / 100	700 / 100
Stroke Length	5	5	5	5	5
Strokes per Minute	25-40	25-40	25-40	25-40	25-40
Air Inlet	¾"	¾"	¾"	¼"	¼"
Water Inlet	¾"	¾"	¾"	¾"	¾"
Overflow Outlet	¾"	¾"	¾"	¾"	¾"
Drain	2"	2"	2"	2"	2"

OPTIONS	LKR36	LKR48	LKR60	LKD60	LKD72
Extra Heavy Duty Lift Capacity (Maximum lbs. @ 100 psi)	1,000	900	1,850	1,850	1,750
Pump Agitation (Horsepower)	1½"	1½"	1½"	1½"	1½"
Gallons per Hour	10,000	10,000	10,000	10,000	2 Pumps/20,000
Voltage Options	230V, 460V Hard Wire	230V, 460V Hard Wire	230V, 460V Hard Wire	230V, 460V Hard Wire	230V, 460V Hard Wire
Hertz Phase	60-1 or 3	60-1 or 3	60-1 or 3	60-1 or 3	60-1 or 3
Heating System (Electric Heat) (Range: 60-180F/16-82C)	4.5kW/Htr*	4.5kW/Htr*	4.5kW/Htr*	4.5kW/Htr*	4.5kW/Htr*

\* Up to three Heaters per unit standard, consult factory for other heater options

# Oil Separator



Graymills Oil Separator (OSEP) removes tramp oil from aqueous cleaning solutions. Easily connected to Graymills Turbo-Action and Liftklean parts washers, as well as other manufacturers' immersion tanks.

Standard features : OSEP 5/5S :

- **Extends cleaning solution life**
- **Oil separation** improves parts cleaner operation
- **Continuous oil removal** during the cleaning process; no shutdown required as with skimmers; oil is not redeposited on clean parts
- Returns virtually **oil-free** solution to parts washer
- Automatically draws off collected oil for **reuse or reclamation**
- **Sturdy construction** of heavy grade steel, requires little maintenance. Also available in stainless steel
- **Economical operation** with no moving parts or outside power source

- 1 Inlet valve controls flow at 5 GPM to assure sufficient separation time.
- 2 Oily cleaning solution enters larger separator chamber.
- 3 Tramp oil adheres to polypropylene spheres which are non-wearing and require no replacement.
- 4 Formed droplets separate and rise to the surface to form an oil layer.
- 5 Oil layer gravity feeds to external container for proper disposal, reuse or reclamation. (container not included)
- 6 Separated fluid passes under baffle to second chamber.
- 7 Virtually oil-free detergent solution flows back to parts cleaner.
- 8 Bottom drain facilitates clean-out when required.

OSEP

*Continuous oil removal during cleaning*

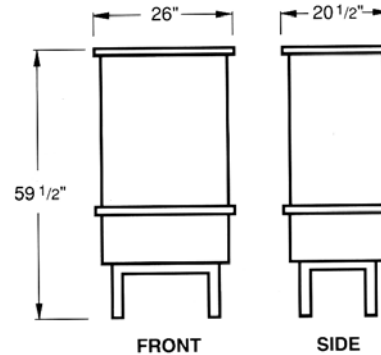

MODELS	DIMENSIONS	CAPACITY	FLOW RATE
OSEP-5/OSEP-5S	30" x 21 1/2" x 59 1/2"	120 gal	5 GPM

The oil separator is intended for water-based cleaning solutions and will not function with solvent-based cleaning fluids. Systems that do not have a recirculation pump require the separator to be equipped with its own pump. Consult customer service for details at 773-248-6825.

## Highly Efficient Oil Removal

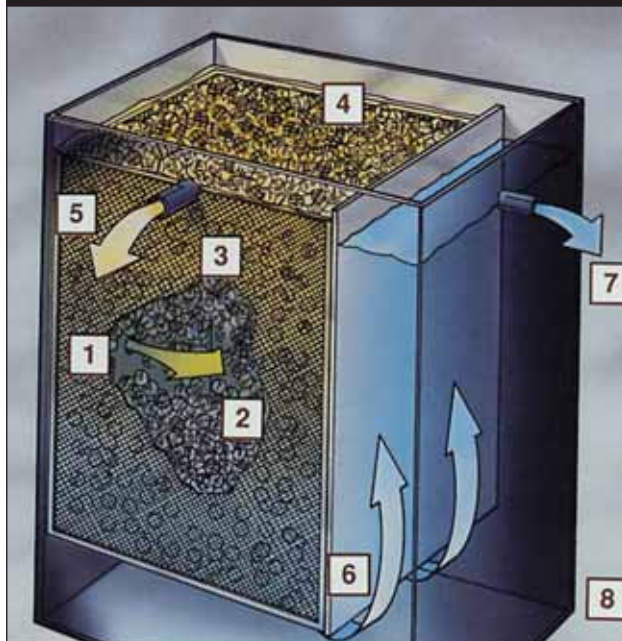



# Turbo-Boost



The Turbo-Boost System draws contaminated aqueous or non-flammable solvent parts cleaning solution through a strainer basket that eliminates large particulate. Remaining contaminants are collected in a replaceable, disposable filter bag. Clean, dual-filtered detergent is pumped back to the parts washer through Turbo-Boost eductor nozzles. Entire fluid volume is continuously filtered every few minutes.

Standard features : TBF :

The Turbo-Boost System for Liftkleen models enhances performance in four ways:

- **Continuous filtration** keeps contaminants from re-settling on already clean parts
- **Clean, filtered fluid is returned** to parts washer through eductor venturi nozzles **increasing cleaning power four times** through additional fluid agitation
- **Increased Turbo Agitation** speeds cleaning cycle by increasing in-tank agitation four times
- Eductor action sweeps tank bottom to **eliminate sludge build-up**
- Life of the **cleaning solution** is greatly **extended**
- **Optional Service Beacon** (shown)

# Roto-Basket



Roto-Basket is an accessory for "T" Series Parts Washers that effectively cleans small parts by creating a gentle, tumbling action to expose all surfaces to the cleaning solution. It is a hands-free cleaning process that reduces labor and saves time.

The tumbler basket assembly consists of a stainless steel expanded metal drum/basket assembly, rotary mechanism and frame assembly. Attaches to the platform of any Graymills "T" Series Liftkleen and holds up to 35 lbs. of parts.

The lift mechanism in the parts washer lowers the basket into the cleaning solution. As the lift platform agitates up and down, the rotating basket turns on a 60° index for every down stroke, thoroughly cleaning the smallest and most fragile parts.

- **Roto-Basket is 100% mechanically driven**—the pawl and ratchet mechanism uses the up and down motion of the lift platform to turn the drum, no electric motors or drives are needed
- **Optional Station makes Load/Unload easy**—separate from the Roto-Basket drive mechanism, the Load/Unload station allows for easy, convenient loading and unloading of baskets
- **System is a drop-in retrofit**—requires only a few minutes to install

PART NUMBER	DESCRIPTION	WEIGHT	DIMENSIONS
TRB-1	Roto-Basket (includes mechanical drive)	26 lbs	20 <sup>1</sup> / <sub>2</sub> " L x 11" H x 13" W
RB-1	Addl. Basket (without mechanical drive)	13 lbs	20 <sup>1</sup> / <sub>2</sub> " L x 11" H x 13" W
Roto-STA	Load/Unload Station	18 lbs	18 <sup>5</sup> / <sub>8</sub> " L x 15" H x 14 <sup>3</sup> / <sub>8</sub> " W

# CUSTOM SYSTEMS



**We will customize a standard model or build you a Special. Just tell us about your cleaning application.**

Look through our catalog and notice the wide range of standard models, from the 5 gallon bench top unit to the 600 gallon Liftkleen. Also notice the number of options available, which include stainless steel tanks and pumps, air powered motors, turbo pump agitation, lift platform agitation, and ultrasonics. Chances are one of these models and its options will meet your cleaning applications.

But maybe your cleaning needs run to the unusual. Does your system require portability, batch cleaning, or multiple-stage processing? Or do you desire a single or multi-tank system? We'll design and build a system for you whether it means simply altering a standard model or creating a one-of-a-kind special. Just contact your Graymills distributor or phone or fax our factory.

**For more information 1-773-248-6825 FAX: 1-773-477-8673**

## Special Model Parts Washers Designed and Built by Graymills

### Automotive Industry

Clean printing bars for speedometer sub-assemblies for cars & trucks.

### Automotive Industry

Tube washer for exhaust systems.

### Aerospace Industry

Multi-stage, multi-process wash system including ultrasonics for sophisticated valve assemblies.

### Printing & Paper Processing Industry

Press parts & anilox roll maintenance.

### Electronic Tool Repair & Refurbishment

Cleaning power tool components before servicing.

### Environmental Alternatives

Equipment specifically designed for use with soy-based solvents.

### Medical Industry

Ultrasonic wash system for machinery maintenance.

### General Industrial

Manufacturing or Repair/Service

# Tempest

aqueous

The Tempest Series of aqueous cabinet parts washers uses 600 psi of high-pressure aqueous cleaning solution power to scrub parts clean—no abrasives to damage precision machined parts.

The ultimate in operator comfort, the Tempest 10/20S keeps the operator's hands clean and out of cleaning solution. Operator simply slips hands into gloves built into hinged front opening door of cabinet, picks up part and adjustable spray nozzle and directs 600 psi fluid stream of heated cleaning detergent at parts where it is needed most.

Fast heat-up, illuminated cabinet and window-clearing blower are standard on both units. Flexible neoprene gloves, safe and convenient air-actuated on/off foot pedal switch, and ergonomic working height maximize user comfort and result in increased efficiency. Adjustable hand-held spray nozzle can be set to a wide fan or pinpoint stream to direct cleaning power where needed. 150 mesh filter traps chips and solids and continuously filters fluid.



Tempest allows you to direct the high pressure detergent stream where needed.

#### Standard Features : both models :

- **600 PSI** and **180 GPH, 1 HP pump** delivers cleaning power directly onto parts
- **1,000 watt heater** (Tempest 10) / **1,500 watt heater** (Tempest 20S) provide heated aqueous fluid that **cleans without grit**
- **Window blower clears detergent and spray** for parts viewing to provide uninterrupted view for efficient, accurate cleaning
- **Hinged front** opening door allows **full access** to entire cleaning chamber

#### Standard Features : Tempest 10 :

- **36" W x 23" D x 23" H** work chamber
- **10 gallon** solution reservoir; **easy-to-change internal pail** fits neatly below spray cabinet
- Available in **mild** or **stainless steel** cabinet

#### Optional Features : Tempest 10 :

- Built in **Air blow-off nozzle** for parts **drying**

#### Standard Features : Tempest 20S :

- **36" W x 38" D x 24" H** large capacity work chamber
- **Stainless steel** cabinet
- **20 gallon** rollout stainless steel reservoir makes fluid changes easy

#### Optional Features : Tempest 20S :

- Built in **Air blow-off nozzle** for parts **drying**
- **Oil skimmer**
- **Workload turntable**

TEMPEST  
10/20S

600 PSI directed stream spray cabinet cleans parts without using grit or abrasives

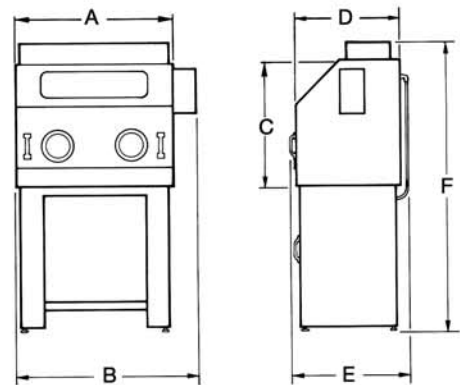

MODEL NO.	A	B	C	D	E	F
TEMPEST 10	36"	41"	22 <sup>1</sup> / <sub>2</sub> "	23"	27 <sup>1</sup> / <sub>2</sub> "	64"
TEMPEST 20S	36"	41"	24"	38"	42 <sup>1</sup> / <sub>2</sub> "	66"

\* Height with door open is plus 7"

SPECIFICATIONS	TEMPEST 10	TEMPEST 20S
Parts Load (maximum)	500 lbs.	500 lbs.
Operating Fluid Capacity	10 gal	20 gal
Spray Pressure	600 psi	600 psi
Motor/Heater-Power	1 HP/1,000W 1 Ph, 115V, 60 Hz	1 HP/1,500W 1 Ph, 115V, 60 Hz

# Drum Mount

Graymills heated drum-mount aqueous model with stainless steel sink and lid offers features and durability that will keep it functioning for years to come.

With a filtered stream of 115° F (46° C) aqueous cleaning solution, the DH226 flushes away loosened soil as parts are brushed clean. With easy setup and minimal maintenance, this unit offers a long, user-friendly service life.



## DH226A

*Heated aqueous drum mount parts washer offers on job-site parts cleaning convenience*

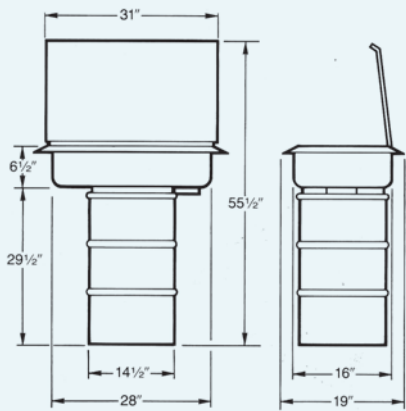

MODEL	OPERATING FLUID CAPACITY	DRUM CAPACITY	MOTOR	HEATER
DH226-A	8-12 gal	16 gal	115V, 60Hz, 1 Ph	115V, 1500W, 15A Lighted On/Off Switch

### Standard features : DH226A :

- **Thermostatically controlled heater** delivers heated solution up to 115° F (40° C)
- **300 GPH pump** and **12 gallon** fluid capacity
- **Flexible Stay-Put flush hose** for directable hands-free flushing action
- **Lift-off stainless steel sink** mounted on drum for easy job site cleaning and maintenance
- **Fusible safety link** closes lid in the event of a fire

### Optional feature : DH226A :

- **Drum Liners** make for easy cleanup of solution reservoir prevent corrosion in drum



## PH822

*Rugged 4-legged aqueous parts washer—sink can be used as soak tank*

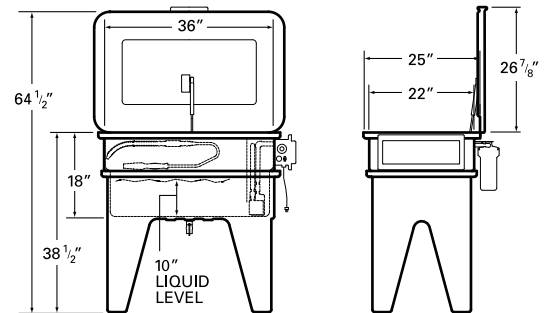

### Standard features : PH822 :

- **Thermostatically controlled heater** delivers heated solution up to 120° F (48° C)
- **Rugged thermoplastic corrosion-resistant** construction is backed by five-year warranty
- **Flow-Thru brush, flexible Stay-Put nozzle**—brush or flush away soil with **300 GPH pump**
- **Low liquid level** shuts off heater in event liquid level drops below a setpoint
- **GFCI** shuts entire unit down in event of electrical short
- **Triple Action Filtration** is achieved by a pump pre-filter, stainless steel strainer and polypropylene cartridge.

### Additional features : PH822 :

- **10" soak depth** tank; molded bottom ridges allow soaking parts with **detergent circulation** while parts sit above sludge
- **Removable stainless steel work shelf**

# Site Washers



**DH536R** *Rugged aqueous parts washer features stainless steel backplash (no lid)*

**DH436R** *Rugged aqueous parts washer with lid and safety link closure*

Standard features : DH436R / DH536R :

- Heated aqueous 102° (39° C) fluid circulates at 300 GPH
- Rugged thermoplastic non-corrosive construction and is backed by five-year warranty
- Flow-Thru brush, flexible Stay-Put nozzle to brush or flush away soil
- Low liquid level shuts off heater in event liquid level drops below a setpoint
- GFCI shuts entire unit down in event of electrical short
- Triple Action Filtration is achieved by a pump pre-filter, stainless steel strainer and polypropylene cartridge
- Stable base is fluid reservoir; removable sink and power module for simple setup, maintenance and service
- Indicator lights for Power On, Heater On, Low Water Shut Down
- 30 gal capacity reservoir—lift-off sink

SPECIFICATIONS	PH822	DH536R	DH436R
Overall Dimensions (L x W x H)	43" x 31" x 40" (65" H Open Lid)	39" x 31" x 43"	39" x 31" x 43" (68" H Open Lid)
Working Space (L x W x D)	31" x 22" x 17"	36" x 22" x 9"	36" x 22" x 9"
Parts Load (max.)	300 lbs.	300 lbs.	300 lbs.
Soaking Depth	10"	N/A	N/A
Operating Fluid Capacity	25 gal	20-30 gal	20-30 gal
Pump	Submersible	Submersible	Submersible
GPH	300	300	300
Horsepower	1/40	1/40	1/40
Heater	1.4 kW	1.4 kW	1.4 kW
Operating Temperature	Up to 120° F	102° F	102° F
Electric Configuration	115V, 1-Phase, 60 Hz	115V, 1-Phase, 60 Hz	115V, 1-Phase, 60 Hz
Shipping Weight	150 lbs.	150 lbs.	150 lbs.

# BIOREMEDIATION

**Super Biotene  
Cleaning Fluid** + **Microbial  
Bio-Pack** + **Biomatic  
Parts Washer** = **Environmentally  
Cleaned Parts**

**The Biomatic Parts Washing System is more than individual products—  
it is a total environmental cleaning system.**

The simplest explanation of how the Biomatic parts washer works is: the Super Biotene cleaning solution cleans the parts while the active microbial action cleans the fluid. This bioremediation process takes place within the parts washer solution reservoir. The microbes work by actually breaking down the hydrocarbon contaminants into their component parts—water (H<sub>2</sub>O) and carbon dioxide (CO<sub>2</sub>) leaving the Biotene cleaning solution free of oily, greasy contamination that can affect clean parts.

When parts are placed in the parts cleaner, the heated Super Biotene™ lifts the grease and grime from the part. A Flexible Stay-Put nozzle and Flow-Thru brush aid the solution in the removal of especially stubborn oil, grease, and other contaminants.

Solution contaminated during this parts washing process flows through a triple filtration system; entering the cleaning solution reservoir first through a pre-filter/vapor barrier, then through a wire mesh stainless steel filter eliminating solid particulate as small as 50 microns. The microbes in the system go to work converting the grease and oil in the reservoir fluid into carbon dioxide and water. The remediated solution then passes through a polyester final filter before being reused in the parts washing process.

Hydrocarbon-busting microbes first gained recognition when they were used to safely assist the cleanup of the Exxon Valdez spill in 1989. The microbes used in the Biomatic System are very similar to their now-famous cousins!

Comparable microbes have been successfully used in petrochemical and chemical plants, refineries, food processing plants, marine barge bilges, machine shop parts washers, truck washers, wood treating plants, ground water remediation and septic tanks.

The Biomatic System **features**:

- **Degrades oil, grease** and a wide variety of **hydrocarbons**
- Contains microbes that degrade hydrocarbons and changes them **into harmless byproducts**
- Establishes a **self-sustaining**, long-lasting colony of harmless microbes
- **Prevents deterioration** of cleaning solutions cutting power

The **benefits**:

- **Solves waste disposal problems** right in the parts washer—solves the problem, does not just move it downstream
- **Safe** for humans and the environment
- **Contributes to source reduction** by limiting accumulation of potentially hazardous wastes in the workplace

# Biomatics

These heated parts cleaners use hydro-carbon converting microbes to reduce solid waste and virtually eliminate fluid disposal. The hydro-carbon converting microbes are added to the cleaning solution and break down oils, grease and other organic impurities into water and carbon dioxide. The advantage for users is that the cleaning fluid almost never needs replacing.

The bioremediation process is greatly helped by a built-in tank solution aeration system that increases the effectiveness of the microbes. This self-sustaining system reduces your dependence on cleaning solution changes and recycling companies.

Constructed of the same thermoplastic as our DH 436/536 Series, the BIO Series uses the same cleaning processes of Flow-Thru brush or flexible Stay-Put nozzle, shares a flow control valve, plus similar three piece (base, sink and power module) construction and 300 lb. capacity. The cleaning solution is held at a constant 102° F for optimum cleaning effectiveness and system maintenance.



bioremediation/aqueous

Our special pH neutral Biotene cleaning fluid and microbe system ensures an extended life for cleaning fluids without costs to change or dispose of fluid. The warm detergent is mild and pleasant to work in, and replacement filters and microbe packages are available to re-invigorate fluids.

BIO436R/536R	
<i>Parts washers offering an environmentally friendly way to clean parts</i>	
SPECIFICATIONS	BIO436/536
Load Capacity	300 lbs.
Overall Dimensions (L x W x H)	39" x 31" x 43" (H no Lid, 536) (68" H with Lid, 436 only)
Dimensions (L x W x H)	36" x 22" x 9" sink
GPH	300
Fluid Capacity	30 gal
Cleaning Solution Temperature	102° F

#### Standard features : BIO436R/536R :

- Bioremediation process **turns grease/oil and organic substances into water and carbon dioxide**, eliminating most fluid changes caused by increased saturation of organic contaminants
- **3-way control valve**, Flow-Thru brush and flexible Stay-Put hose for brush and flush cleaning
- **Rugged thermoplastic** construction provides long service life; backed by five-year warranty
- **pH neutral** cleaning solution has **USDA and SCAQMD** approval
- **Low liquid level warning** and **Ground Fault Circuit Interrupter** shuts off power to heat in event of liquid level drops below a certain point; GFCI shuts entire unit down in event of electrical short or malfunction
- **Nine-inch deep** sink, **300 pound** capacity and **30-gallon** reservoir
- **Triple Action filtration** removes non-organic impurities
- Power module with **indicator lights** for Power On, Heater On, Low Water shutoff
- **BIO accessories** include filters and Microbe Bio Pack

# ULTRASONIC

## What is Ultrasonics?

The science of ultrasonics is the study and application of mechanical vibrations above the range of human hearing—typically greater than 18,000 HZ.

## What is Ultrasonic Cleaning?

Ultrasonic cleaning uses ultrasonic energy in an immersion cleaning tank to assist in the removal of tenacious or stubborn soils from parts.

An ultrasonic system always consists of at least three main components:

- 1 A tank to hold the cleaning fluid and the dirty parts
- 2 A generator to transform the line voltage into an ultrasonic signal
- 3 Transducers to convert the ultrasonic electrical signal into mechanical energy

## What is an Ultrasonic Generator?

The ultrasonic generator takes AC electrical energy from the power line and converts it to electrical energy alternating at the desired ultrasonic frequency. In addition, the ultrasonic generator may have complex circuitry which automatically tunes its output to the optimum operating frequency for the ultrasonic transducer.

## What is an Ultrasonic Transducer?

A transducer converts electrical energy at the ultrasonic frequency to mechanical motion—sound. It directs the sound energy into the cleaning tank.

## What is Cavitation and Implosion?

The phenomenon of cavitation is unique in fluids. The cavitation bubbles implode, releasing locally high energy. This implosion is the heart of the ultrasonic process.

## How does Ultrasonic Cleaning Work?

An ultrasonic system works by inducing controlled cavitation in the cleaning fluid. Cavitation refers to microscopic voids or “bubbles” that form when the transducers emit sufficient ultrasonic energy into the fluid. The cavitation bubbles form relatively slowly and then collapse suddenly, releasing tremendous energy against the surfaces of objects immersed in the tank that ‘scrubs’ hard to remove soils from the parts.

# Benchtop Series

The stainless steel, corrosion-resistant tanks come in three sizes, and the thermostatically controlled tank heaters maintain a temperature optimized for cleaning. Because the ultrasonic generator is an integral part of the cabinet housing, their small footprint makes these units ideal for job site “cell” cleaning applications or places where space is critical.

### Standard features :

- Choose from **Three tank sizes** for parts up to 12" W x 16" L
- Bonding of **transducers** is **guaranteed for 10 years**
- All units have **1/2" drain fitting**
- **Lift-off cover with handle**
- **Adjustable thermostat** optimizes tank temperature of individual parts up to **160° F**
- **Sound-deadening** insulation package
- **Illuminated controls** for ultrasonics and heater function

### Options include :

- **Stainless steel mesh parts basket**



MODEL	TANK CAPACITY	ULTRASONIC POWER	HEATER POWER	TANK DIMENSIONS (L x W x D)	OVERALL DIMENSIONS (L x W x H)
BTU-4	4 gal	250W/500W Peak	500W/120V	12"x 8" x 10"	16" x 18 x 16 <sup>1</sup> / <sub>4</sub> "
BTU-7	7 gal	500W/1000W Peak	500W/120V	14" x 11" x 11"	18"x 21"x 17 <sup>1</sup> / <sub>4</sub> "
BTU-17	17 gal	750W/1500W Peak	1,000W/120V	20" x 14" x 14"	24"x 24"x 20 <sup>1</sup> / <sub>4</sub> "



# Sonic Liftclean

Graymills unique high intensity "V-focused" ultrasonic sound increases cleaning power and speed for intricate parts as well as large industrial pieces.

T24U

*Economical but powerful ultrasonic cleaning system*

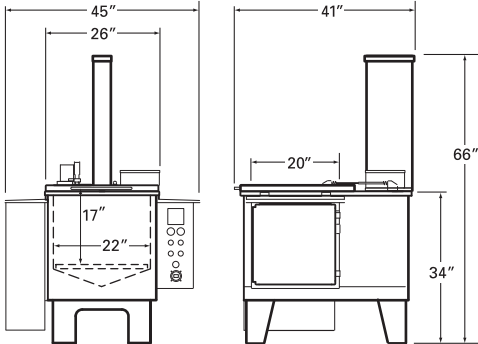

MODEL	FLUID CAPACITY	LIFT CAPACITY	ULTRASONIC POWER	HEATER POWER
T24-U	47 gal	120 lbs.	4,000W/230V, 1 Ph	6.75 kW

## Typical Ultrasonic Cleaning Applications

Ultrasonic works for removal of insoluble particulate soils, or soils that tenaciously hold to the parts, including:

**Compounds** (Grinding, Lapping, Buffing, Honing) >  
**Carbon** > **Corrosion** > **Coatings** > **Paint** > **Ink**

Excellent for cleaning of complex parts where the small size or intricate construction restrict cleaning by ordinary means:

**Small Assemblies** > **Nested Parts** >  
**Blind Holes** > **Tapped or Threaded Bodies** >  
**Complex Machined Parts**



- > Deep "V" tank bottom focuses the ultrasonic power on the work load
- > Bonding of transducers is guaranteed for 10 years
- > Air operated lift platform handles loads up to 120 lbs with ease; gentle up and down agitation while submerged enhances the cleaning process
- > Adjustable, thermostatically controlled tank heaters maintain optimum cleaning solution temperature up to 160° F
- > Digital cycle timer controls cleaning cycle start and stop times
- > Oil skimmer removes oil from cleaning solution
- > Lift platform raises to the top of the immersion tank, for easy access to load and unload parts
- > Corrosion-resistant MIG welded stainless steel construction is designed for longevity.
- > Double walled insulated tank and lid prevents heat loss and evaporation
- > Small foot print is ideal for on site "cell" cleaning and can be combined with other units (rinse tanks, dryers) to complete the cleaning process
- > Stainless steel tanks

ultrasonic/aqueous

# Super Sonic Lift



**The Super Sonic Liftkleen parts washer features full immersion cleaning coupled with powerful ultrasonics to thoroughly wash the most difficult to clean parts.**

- **Full PLC Control** with Touch Screen Operator Interface provides programmable cycles for **ultrasonics, platform oscillation, soak, sparger, filtration** and **heater** functions up to 180°F
  - **Ultrasonic frequency sweep** continuously changes sound patterns to help prevent parts damage
  - **Heavy duty immersible sealed transducers** evenly distribute the ultrasonic sound waves and eliminate cleaning blind spots
  - **Pneumatic lift platform** allows easy loading/unloading of parts **up to 300 pounds** and offers **agitation capabilities** for thorough parts cleaning
  - **Automated lid open/close** via pneumatic cylinder allows for hands-free operation
  - **Built in weir and surface sparger** system removes floating oil and debris from the top of cleaning solution so parts are not dragged through the floating contaminant at the end of the cleaning cycle
  - **Oil skimmer** removes oil from weir chamber
  - Filtration system **constantly filters the cleaning solution** to extend bath life for more consistent cleaning
  - **Double walled, fully insulated stainless steel tank and lid** prevents heat loss, evaporation and reduces noise
  - Bottom drain and valve for **easy change out** of cleaning solution
- Units available without Ultrasonics. Please contact factory

# kleen

The TUS3725SL-model comes equipped with features to achieve ultimate parts cleaning levels. It is built to withstand rugged use in applications like engine rebuilding, performance racing, maintenance and manufacturing, but gentle enough to be used in the most delicate of cleaning applications.



PLC controls cycle times, ultrasonic wash time, the time for surface sparger spray to come on after the timed ultrasonic cleaning cycle and the operation of the lift platform.



Three ultrasonic generators deliver 6,000 watts of peak power

TUS3725SL	
<i>Ultimate performance Ultrasonic parts washer</i>	
SPECIFICATIONS	TUS3725SL
Immersion Space (L x W x D)	37" x 25" x 14" (max. part size)
Overall Dimensions (L x W x H)	55" x 66" x 72"
Liquid Capacity	183 Gallons
Standard Lift Capacity/PSI	300/100
Stroke Length	4"
Strokes per Minute	25-40
Air Inlet	3/8" NPT
Water Inlet	3/4"
Drain	1 1/2"
Heater Setting Range 0-180°F (Unit cannot cool below ambient temperature)	4kW/Htr 8kW/Htr (optional second heater bank)
Ultrasonic Cleaning Power	RMS 3,000 watts total (Three generator/transducer units @ 1,000 watts each) Peak 6,000 watts total

ultrasonic/aqueous



Heavy duty immersible drop-in sealed transducer packs.



Built-in oil removing weir and surface sparger system ...



... removes floating oil and debris from top of cleaning solution so parts are not dragged through the floating contaminant at the end of the cleaning cycle.



Skimmer removes oil from Weir Chamber—increases solution life.

# ACCESSORIES

## General Purpose Parts Baskets



**L-3** Permits flushing of small parts while keeping them organized. 10" diameter

**L-7** Hooks over edge of tank or stands on legs. 8" L x 6" W x 4" H

**L-8** Expanded metal on sides and bottom. 13" L x 12" W x 5" H

**5B-1** sized and bracket for use with standard five gallon pail

## Detergent Neutralizer System



System enables users to treat water-based aqueous detergent solutions for sewer disposal. Oil absorbent pads pick up floating oil. Detergent neutralizer powder to treat used solution to meet Federal and local disposal regulations. 18" by 18" oil pads absorb up to 25 times their own weight in oil. Neutralizer powder changes color of solution when sufficient powder has been added. Pads and powder can be purchased separately or in kit form.

*NOTE: For first-time use, laboratory-analyzed sample of neutralized solution should be submitted to your local authority to assure that your processed fluid waste meets their standards.*

## Clean-O-Matic Baskets

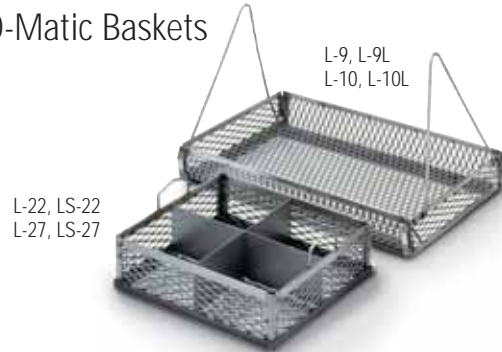

**L-9** Clean-O-Matic 900 and 902-perforated metal sides and bottom with 15 gauge frame for heavy-duty use; can be supported above liquid level for draining by special pull-out supports, 32" L x 17" W x 5" H

**L-9L** Same as L-9 except with sturdy lifter bar to permit use with chain hoist for heavy-duty work

**L-10** Same as L-9 in larger size for Turbo-Action parts cleaners, 34" L x 21" W x 5" H

**L-10L** Same as L-10 with lifter bar

## Liftkleen Baskets

Perforated metal sides, bottom and iron frame. Removable dividers facilitate handling of variety of sizes.

**L-22** and **LS-22** (stainless) 22" L x 18" W x 6" H

**L-27** and **LS-27** (stainless) 31<sup>1</sup>/<sub>4</sub>" L x 23<sup>1</sup>/<sub>4</sub>" W x 6" H

Actual basket material may differ from photo

## L-Series Liftkleen Baskets

**LKB36** and **LKBSS36** (stainless) Parts Basket for LKR36 32" L x 19" W x 15" H

**LKB48** and **LKBSS48** (stainless) Parts Basket for LKR48 44" L x 31" W x 15" H

**LKB60** and **LKBSS60** (stainless) Parts Basket for LKR60, LKD60 55" L x 31" W x 15" H

**LKB72** and **LKBSS72** (stainless) Parts Basket for LKD72 67" L x 37" W x 15" H

## Work Light



Constructed with 360° rotation and a 28" gooseneck to allow for additional lighting of entire work area. Solid support so light cannot be pulled down to obstruct cover closing in case of fire. For HK-150, all Handi-Kleens, and all Clean-O-Matics. Mounts to back or side of tank.

## Work Shelves

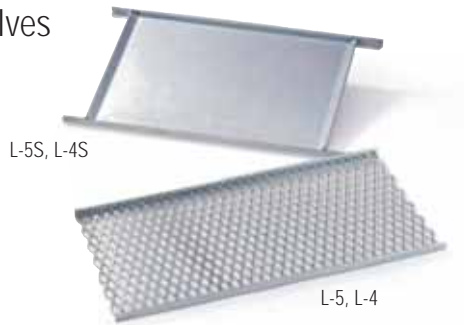

Shelves shown here are supplied as standard with the purchase of one of the listed parts cleaners. Ideal for additional work space or replacement of worn shelves.

**L-5** Perforated metal Flo-Thru shelf constructed with solid metal frame; for use with Clean-O-Matic Models 300 and 500

**L-4** Identical to L-5 but sized for use with Clean-O-Matic Model 800

**L-5S** 16 gauge steel shelf for use with Clean-O-Matic Models 300 and 500

**L-4S** Identical to L5S but sized for use with Clean-O-Matic Model 800

Actual shelf material may differ from photo

## Drain Shelves



Accessory shelves designed to provide a working platform that allows cleaned parts to drain while directing run-off into tank. Shelves mount externally to maintain critical workspace.

**L-6** 16 gauge steel shelf attaches to side of Clean-O-Matic Models 300, 500 and 800. 16" L x 18" W

**L-61** 16 gauge steel shelf mounts to side of Flo-Bac, HK-150, and all Handi-Kleen models. 15" L x 18" W

## Brushes



**3B-G** Standard brush with 2 1/2" polypropylene bristles

**5D** Double brush, with 1 1/2" and 2 1/2" nylon bristles

**6A** Flow-Thru brush flushes part as it cleans. Solvent flows through core of handle; 2" Connecting hose, 2 1/2" nylon bristles, and a rubber connector that slips over nozzle of flexible metal hose of parts cleaner

**7-A** Flat Angular Flow-Thru cleaning brush can attach to pump nozzle with rubber hose (included)

**8-A** Round Angular handle cleaning brush can attach to pump nozzle with rubber hose (included)

## Filters

Filtration systems are available for all Liftkleen Models. Filters for T-series models available in 10, 50 and 100 micron. For L-series models in 150 and 590 micron. See GM price list.



## Replacement Filter Bags

Replacement filter bags for Drum Mount Parts Cleaners.

**C-27360** washable nylon mesh filter bag extends solvent life, 12 per package



## Drum Liners

Poly bag liners simplify cleanup and disposal of solid waste. Available in dozens.

**C-27452** Fits 16 gallon drum mounts

**C-27484** Fits 30 gallon drum mounts

**C-27835** Fits Tempest 10



# CLEANING FLUIDS

Graymills fluids are specially formulated to provide optimum cleaning in our parts washers. They are intended to be used for a variety of cleaning needs, and specific formulations are available for cleaning ferrous and non-ferrous metals, rubber and elastomers, parts to be painted, and for removal of many varieties of grease, motor oil, cutting fluids, carbon deposits, inks and gummy residues.

## General Purpose Solvents



### Super Agitene

Ideal for cleaning of metal, plastics and painted surfaces. Grease, motor oil, cutting oil and water soluble oils are removed with ease. Gummy deposits unaffected by ordinary mineral spirits are readily softened or removed. Contains Hand Ease® a cosmetic-grade lanolin formulation, which replenishes some of the skin's natural oils removed by solvents. It helps to reduce the chance of irritation and chapping and leaves a protective coating on parts to help retard corrosion, and is a low-odor solvent with a 105° F flashpoint. It should not be used on parts going into a plating or painting process. (See regular Agitene.) Available in 5 gallon pails and 50 gallon drums.

### Super Agitene 141

- Contains **no ingredients** listed as **hazardous** by the EPA's RCRA
- Meets OTC VOC regulations

Has the same attributes as Super Agitene but a higher flash point of 141° F (60° C), which meets local regulations where use of High Flash Point Solvent is required. Available in 5 gallon pails and 50 gallon drums.

### Regular Agitene

Same high quality cleaning action as Super Agitene, but leaves no film thus making it ideal for cleaning parts to be painted. It will not attack varnish, allowing it to be used on varnish-insulated electrical components. Available in 5 gallon pails and 50 gallon drums.

## Solvent Filtration



### Solvent Saver Filters

Extend the life of solvent cleaning solutions by filtering out the oil and grease that accumulates in the solvent cleaning solution.

- **Fits all regular** drum-mount and free-standing solvent parts washers
- **Easy installation** rubber hose with **universal adapter** fits over end of flexible Stay-Put nozzle
- Replace on an **"as-needed"** basis
- **Maintains cleaning solution** at a consistent level of performance

### Solvent Saver I

Oil and Grease Removal (Packed two/carton)

**SS-11** 7" diameter x 11" long includes one connecting hose

**SS-18** 7" diameter x 18" long includes one connecting hose

### Solvent Saver II

Oil and Grease Plus Particulate Removal (Packed two/carton)

In addition to special absorbent materials, it contains a 5 micron filter cartridge that filters particulate from the solvent prior to oil and grease absorbing stage.

**SSC-11** 7" diameter x 11" long—includes one connecting hose

**SSC-18** 7" diameter x 18" long—includes one connecting hose

### For Solvent Saver I and II

Solvent Saver Hanging Bracket—Stainless Steel bracket holds filter out of way on inside of parts washer.

**SSC-BRAC** 12" long x 9" deep x 8" high

## Biodegradable Alkaline (Aqueous) Cleaners

Graymills versatile line of aqueous cleaners can be used for removing virtually any organic or inorganic soil, including greases, oils, soft carbons, epoxies, hard water residue, corrosion, oxides, paints, plating salts, rust and smut. Aquatene water-based cleaners work most effectively when heated and require only a water rinse.



### Aquatene 330

A general purpose concentrated detergent in liquid form. Works best when heated up to 140° F (60° C). Ideal for use in free-standing manual systems and immersion type part washers. Removes soft carbon deposits, light coatings, grease, gummy residue, oils, latex paint, light varnishes, rust preventitives. A five gallon pail makes 25-50 gallons; a 55 gallon drum makes 275-500 gallons, depending on concentration.

### Super Aquatene 360

A general purpose concentrated cleaner in liquid form can be used up to 180° F for faster cleaning. Ideal for use in free-standing manual systems and immersion type part washers. Removes all items listed for GM 330 but also effectively cuts buffing and lapping compounds, hard to remove coatings, water-based inks, oxidized oils and heavy or burned-on varnishes. A five gallon pail makes 25-50 gallons of cleaner; a 55 gallon drum makes 275-500 gallons of cleaner, depending on concentration.

### Super Aquatene 390

A heavy-duty, low-foam concentrate perfect for use in spray cabinet washers. Ideal for steel, cast iron, and other ferrous metals (not for use on non-ferrous metals). Removes most greases, light oils, water soluble inks, hardened composites and loose metal chips. Contains a rust inhibitor. A five gallon pail makes 30-40 gallons, a 55-gallon drum makes 300-450 gallons, depending on concentration. Heat to maximum of 150° F.

### Aquatene 571

Specially formulated for cleaning aluminum and non-ferrous metals. The powdered compound mixes @ 3 to 8 ounces per gallon of water. Available in 25 lb cartons or 100 lb. Fiber drums. Use heated to 180° F (82° C).

### Super Biotene 660 (Pre-blended) and Super Biotene 550 (Concentrate)

Super Biotene is an aqueous-based solution that is pH neutral (7.0) mixture of emulsifiers and surfactants containing no VOCs. It is designed for our Bioremediation models, although it is a good general cleaner that can be used in other parts washers. Available in one quart liquid concentrate that makes five gallons of cleaner. One gallon liquid concentrate that makes 21 gallons of cleaner and five gallon pail of pre-blended, ready-to-use formula.

# Cleaning Fluid Reference Chart

Cleaning Problem	Super Agitene	Regular Agitene	Aquatene 330	Super Aquatene 360	Aquatene 390	Aquatene 571	Super Biotene
Buffing and Lapping	*	*		*	*		
Carbon Deposits, Soft			*	*	*	*	*
Coatings, Light	*	*	*	*	*	*	*
Grease	*	*	*	*	*	*	*
Gummy Residues	*	*	*	*	*	*	*
Inks, water based				*			
Oils	*	*	*	*	*	*	*
Oils, oxidized				*	*	*	
Paint, Latex			*	*	*		*
Paint, Oil based	*	*			*		
Rust Preventatives	*	*	*	*	*	*	*
Varnishes, Light	*	*	*	*	*	*	*
Varnishes, Heavy				*	*	*	
Varnishes, Burned-On				*	*	*	
Waxes			*	*	*	*	*

For Use in:	Super Agitene	Regular Agitene	Aquatene 330	Super Aquatene 360	Super Aquatene 390	Aquatene 571	Super Biotene
Clean-O-Matic	*	*					
Handi-Kleen (cold)	*	*					
Handi-Kleen (hot)			*	*		*	
Turbo Parts Cleaner (cold)	*	*					
Turbo Parts Cleaner (hot)			*	*	*	*	
Liftkleen (cold)	*	*					
Liftkleen (hot)			*	*	*	*	
Spray Washing Cabinet			*	*	*	*	
Tempest			*	*	*	*	
Drum Mount (cold)	*	*					
Drum Mount (hot)			*	*		*	
Ultrasonic			*	*			
Biomatic							*



## Graymills manufactures pumps

for most industrial applications including machine tools for the global marketplace. Visit the website or call customer service for literature on Graymills centrifugal, gear, diaphragm, high pressure multi-stage pumps and tank systems for OEM and MRO applications.

# Graymills

Worldwide Distribution and Product Support

Graymills Corporation  
 3705 N. Lincoln Ave.  
 Chicago, Illinois, 60613-3594  
 Phone: 1-888-GRAYMILLS  
 Fax: 1-773-477-8673  
 www.graymills.com